

## TDS-9.5C



- Heavy duty series wound motor delivers superior torque output and faster line speed.
- 3 stage planetary gearbox delivers the most reliable and durable performance of winch under the worst condition.
- Automatic, double cone brake.
- Rotating ring gear clutch have the free spooling positioned actually for the rapid pay out of wire rope with ease.
- Installation, operation and maintenance with ease.



## Detailed Data:

## SPECIFICATION

**Line pull:** 4,309kgs/9,500lbs

**Motor:** 12V/5.0HP 24V/3.0HP

**Gear Train:** Three stage

**Gear Ratio:** 173:1

**Freespooling Clutch:** Rotating ring gear

**Wire Rope Size:**  $\Phi 11/32" \times 100'$  ( $\Phi 8.7\text{mm} \times 30\text{m}$ )

**Wire Rope Type:** Aircraft A7 $\times$ 19

**Drum Size:**  $\Phi 2.5" \times 9"$  ( $\Phi 63.5\text{mm} \times 229\text{mm}$ )

## LINE PULL

Layer of Wire Rope	Max Line Pull
1	9,500lbs/4,309kgs
2	7,800lbs/3,500kgs
3	6,550lbs/2,977kgs
4	5,700lbs/2,578kgs

## LINE SPEED AND AMP DRAW (1st layer of rope on the drum)

Load	Line Speed	AMP Draw(12V)	AMP Draw(24V)
No Load	55.8FPM/17MPM	60	40
2,000lbs/907kgs	14.7FPM/4.5MPM	140	106
4,000lbs/1,814kgs	12.5FPM/3.8MPM	181	158
6,000lbs/2,722kgs	12FPM/2.7MPM	248	187
8,000lbs/3,650kgs	8.2FPM/2.5MPM	295	226
9,500lbs/4,309kgs	7.5FPM/2.3MPM	338	259

## DIMENSIONS(mm)

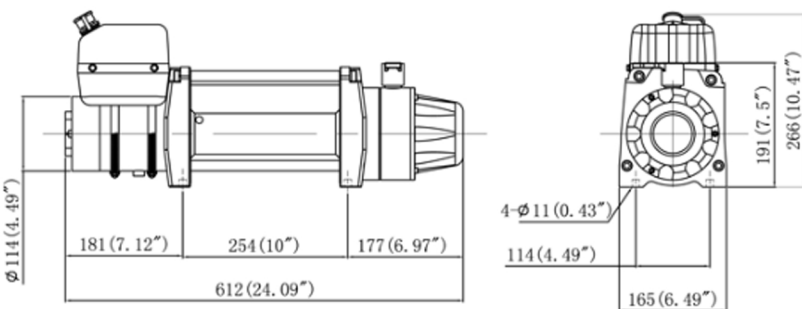

## STANDARD ACCESSORIES

Controller	TA-0906
Wire Rope With Hook	
4 Way Roller Fairlead	TA-0903
Control Unit	TA-0910
Mounting Hardware	
Pulley Block	TA-0109
Handsaver Strap	

## PACKAGE

**Winch weight :** 48kgs/106lbs

**Gross Weight :** 50kgs/110lbs

**Box Dimension :** 647 $\times$ 198 $\times$ 440 mm(25.5" $\times$ 7.8" $\times$ 17.3")